

CORMAC B

Basic reel with manual or electric drive



The MacArtney portfolio of winch and handling systems includes the CORMAC B range of basic cable reels.

CORMAC B comes with a manual drive as a standard but is also available with hand crank or electric motor drive. The reels are easily modifiable to accommodate a variety of tasks and applications. Further adding to the flexibility of CORMAC B reels, all systems are designed to be lightweight and portable.

CORMAC B reels are primarily used on vessels, barges or rigs to store deck cable under harsh maritime conditions. With frames and drums manufactured from either stainless steel or aluminium, the cable reels are rugged, highly durable and require very little maintenance.

Beyond cable storage, applications for MacArtney CORMAC B reels include the handling of basic inspection class ROV systems, underwater camera systems, general oceanographic instrumentation, diver communication lines and general marine instrumentation.

CORMAC B reels hold the capacity to store several types of cable typically with a diameter of 8 to 25 mm and a length of up to 1,700 metres - depending on cable diameter. Last but not least, CORMAC B reels are prepared for the integration of a Focal model 180 electric/-electro-optical slip ring.

Highlighted specifications

- Available in stainless steel AISI 304 (sand/bead blasted surface treatment) or aluminium AlMg³ (painted surface treatment)
- Designed for use with a Focal model 180 electric/electro-optical slip ring
- Designed to handle cables with a diameter of between 8 and 25 mm and up to 1,700 metres of length - depending on cable diameter
- Mechanical parking brake
- Delrin® bearings (lifetime lubricated)

Features and benefits

- Lightweight and portable systems
- Low maintenance requirements
- Corrosion resistant
- Rugged design and materials suited for use in harsh marine environments

Applications

- Deck cables for vessels, barges, rigs etc.
- Basic ROV systems (inspection class ROVs)
- Underwater camera systems (including the LUXUS drop plate and various downhole systems)
- Oceanographic instrumentation and sensors (including CTD applications)
- Diver communication lines
- General marine instrumentation

Options

- Hand crank drive, gear box (I = 10:1) and anti run back device
- 0,75 kW motor 1 x 220/230 VAC with gear and electric box including remote control w/10 rubber cable and 30 m rubber cable open ended

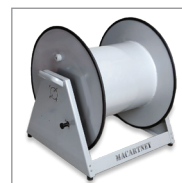

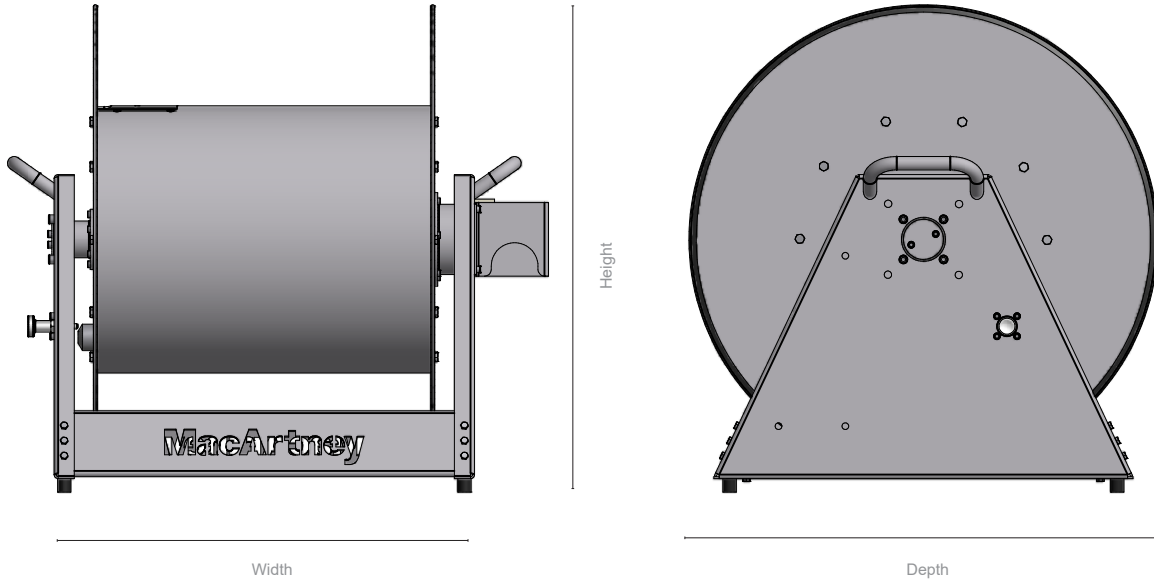

Capacity examples						
Cable OD mm	8	10	14	18	20	25
Length meter	1700	1100	500	250	230	115

CORMAC B

Specifications

CORMAC B - stainless steel version

Material:	AISI 304
Construction:	Bolted frame and flanges
Surface treatment:	Sand/bead blasted
Bearings:	Delrin - self lubricating
Brakes:	Mechanical parking brake
Dimensions:	H: 728 mm W: 809 mm D: 702 mm
Drum dimensions:	Drum: ø400 mm Flange: ø702 mm Length: 500 mm
Max cable weight:	250 kg
Max cable pull:	70 kg
Reel weight:	46 kg
System certification:	None

CORMAC B - aluminium version

Material:	AlMg ³
Construction:	Bolted frame and flanges
Surface treatment:	Painted RAL 9007
Bearings:	Delrin - self lubricating
Brakes:	Mechanical parking brake
Dimensions:	H: 728 mm W: 809 mm D: 702 mm
Drum dimensions:	Drum: ø400 mm Flange: ø702 mm Length: 500 mm
Max cable weight:	200 kg
Max cable pull:	70 kg
Reel weight:	28 kg
System certification:	None